

# HP-1352-F

Planetary Rear Axle  
Double Reduction



MAN planetary axles come from large-scale series production for commercial vehicles and meet the most demanding requirements.

The center section of the axle housing is made of high quality forged steel.

The two axle stubs are secured to the axle housing by method of friction welding.

Together, the bevel gear, the differential, and the ring and pinion gear form an assembly that can easily be exchanged as a complete unit.

Shafts and gears are made of high strength, case-hardened alloy steel and mounted in robust tapered roller bearings.

The wheel hubs are made of nodular cast iron and incorporate the latest technical know-how. The wheel hub bearings are maintenance-free (Hub Unit).

All bearings are oil-lubricated.

The final torque is build up within the planetary hubs by means of five planetary gears running on needle bearings.

The planetary gears are helical cut for further noise optimization.

A differential lock can be supplied for almost all axles on request or retrofitted without difficulty.

The axles are fitted with drum brakes, feature automatic brake shoe adjustment and wear indicators on both, OEM brake linings and slack adjusters.

The brake linings are asbestos-free.

The axle is fitted with an anti-lock braking system (ABS).

Only rims and tires released by MAN may be fitted.

A version for single tires is available upon request.

The brake cylinders are pneumatically actuated and can be included as a customer option in the delivery content of the axle.

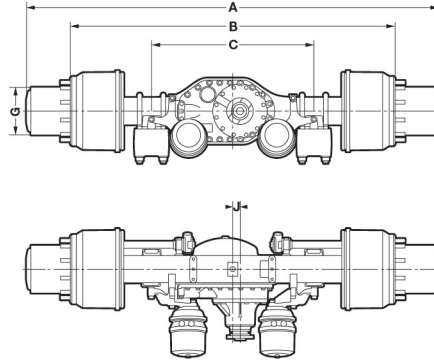

## Technical data

HP-1352-F width 102"

Max. axle load.....	lb.....	28.660
A = Overall width without tires.....	inch.....	93.5
B = Width across brake drums / hubs.....	inch.....	73.46
C = Spring track.....	inch.....	37.01
J = Flange to axle centerline, horizontal.....	inch.....	1.57
Wheel size.....	inch.....	22.50
G = Qty. of wheel studs / hole circle diameter.....	mm.....	10 / 335
Air drum brake / S-cam.....		X
Brake drum diameter.....	inch.....	16.14
Brake lining width.....	inch.....	8.66
Air brake cylinder diameter.....	inch.....	30 / 30
Drive flange diameter cross-serrated.....	inch.....	5.91
Differential lock (on request) .....		X
Weight without wheels, with oil.....	lb.....	1679.92
Ground ring and pinion gear.....		X

**Available ratios:** 4.08 / 4.69 / 5.44

## Contact Us

---

# MAN Engines & Components Inc.

591 SW 13th Terrace  
Pompano Beach, FL 33069  
USA

Phone: (954) 946-9092  
(800) MAN-2842

Fax: (954) 946-9098

Email: [axles@man-mec.com](mailto:axles@man-mec.com)

Web: [www.man-mec.com](http://www.man-mec.com)

